

Scientific Equipment & Furniture Association

**SEFA 8P-2026 - Laboratory Grade
Polypropylene Casework Standard**

**SEFA World Headquarters
1320 Main Street - Ste 300
Columbia, SC 29201**

**Tel: 516-294-5424
www.sefalabs.com**



Table Of Contents

	Page		Page
Committee Members	1	5.0 Doors	8
Foreword	2	5.1 Door Hinge Test	
Sections		5.1.1 Purpose of Test	
1.0 Scope	3	5.1.2 Test Procedure	
2.0 Purpose	3	5.1.3 Acceptance Level	
3.0 Definitions	3	5.2 Door Impact Test	
3.1 Description of Testing Apparatus		5.2.1 Purpose of Test	
4.0 Base Cabinets	6	5.2.2 Test Procedure	
4.1 Description of Test Unit		5.2.3 Acceptance Level	
4.2 Cabinet Load Test		5.3 Door Cycle Test	
4.2.1 Purpose of Test		5.3.1 Purpose of Test	
4.2.2 Test Procedure		5.3.2 Test Procedure	
4.2.3 Acceptance Level		5.3.3 Acceptance Level	
4.3 Cabinet Concentrated Load Test		6.0 Drawers	10
4.3.1 Purpose of Test		6.1 Drawer Static Test	
4.3.2 Test Procedure		6.1.1 Purpose of Test	
4.3.3 Acceptance Level		6.1.2 Test Procedure	
4.4 Cabinet Torsion		6.1.3 Acceptance Level	
4.4.1 Purpose of Test		6.2 Drawer and Door Pull Test	
4.4.2 Test Procedure		6.2.1 Purpose of Test	
4.4.3 Acceptance Level		6.2.2 Test Procedure	
4.5 Cabinet Submersion Test		6.2.3 Acceptance Level	
4.5.1 Purpose of Test		6.3 Drawer Impact Test	
4.5.2 Test Procedure		6.3.1 Purpose of Test	
4.5.3 Acceptance Level		6.3.2 Test Procedure	
4.6 Spill Containment Test		6.3.3 Acceptance Level	
4.6.1 Purpose of Test		6.4 Drawer Internal Impact Test	
4.6.2 Test Procedure		6.4.1 Purpose of Test	
4.6.3 Acceptance Level		6.4.2 Test Procedure	
		6.4.3 Acceptance Level	
		6.5 Drawer Cycle Test	
		6.5.1 Purpose of Test	
		6.5.2 Test Procedure	
		6.5.3 Acceptance Level	

Table Of Contents (cont'd)

	Page		Page
7.0 Shelving	12	9.1 Description of Test Unit	
7.1 Description of Test Unit		9.2 Load Test	
7.2 Shelf Load Test		9.2.1 Purpose of Test	
7.2.1 Purpose of Test		9.2.2 Test Procedure	
7.2.2 Test Procedure		9.2.3 Acceptance Level	
7.2.3 Acceptance Level		10.0 Tables	19
8.0 Cabinet Surface Finish Tests	13	10.1 Description of Test Unit	
8.1 Chemical Spot Test		10.2 Load Test	
8.1.1 Purpose of Test		10.2.1 Purpose of Test	
8.1.2 Test Procedure		10.2.2 Test Procedure	
8.1.3 Acceptance Level		10.2.3 Acceptance Level	
8.2 Hot Water Test		10.3 Table Racking	
8.2.1 Purpose of Test		Not applicable to Polypropylene	
8.2.2 Test Procedure		11.0 Mobile Casework	19
8.2.3 Acceptance Level		11.1 Description of Test Unit	
8.3 Impact Test		11.2 Static Stability Test	
Not applicable to Polypropylene		11.2.1 Purpose of Test	
8.4 Paint Adhesion Test		11.2.2 Test Procedure	
Not applicable to Polypropylene		11.2.3 Acceptance Level	
8.5 Paint Hardness Test		11.3 Static Load Test	
Not applicable to Polypropylene		11.3.1 Purpose of Test	
8.6 Dart Impact Test		11.3.2 Test Procedure	
Not applicable to Polypropylene		11.3.3 Acceptance Level	
8.7 Edge Delaminating Test		11.4 Rolling Stability Test	
Not applicable to Polypropylene		11.4.1 Purpose of Test	
8.8 Edge Impact Test		11.4.2 Test Procedure	
Not applicable to Polypropylene		11.4.3 Acceptance Level	
8.9 Wear Resistance (Abrasion) Test		Endnotes	21
Not applicable to Polypropylene		Appendix 1	
9.0 Wall Cabinets, Counter Mounted and Tall Units	18	SEFA 8 Comparison Chart	22
		Forms	23

SEFA 8-P Committee Co-Chairs

Peter Daniele - LM Air Technology, Inc.
peted@lmairtech.com

Ken Dixon - Air Control, Inc.
kdixon@aircontrol-inc.com

Foreword

SEFA Profile

The Scientific Equipment and Furniture Association (SEFA) is an international trade association comprised of manufacturers of laboratory furniture, casework, fume hoods and members of the design and installation professions. The Association was founded to promote this rapidly expanding industry and improve the quality, safety and timely completion of laboratory facilities in accordance with customer requirements.

SEFA Standards

SEFA and its committees are active in the development and promotion of Standards having domestic and international applications. Standards are developed by the association taking into account the work of other standard writing organizations. Liaison is also maintained with government agencies in the development of their specifications.

SEFA's Standards are developed in and for the public interest. These Standards are designed to promote a better understanding between designers, architects, manufacturers, purchasers, and end-users and to assist the purchaser in selecting and specifying the proper product to meet the user's particular needs. SEFA's Standards are periodically updated. The Standards are numbered to include an annual suffix which reflects the year that they were updated. SEFA encourages architects to specify this Standard as follows: "SEFA 8P-2020" Lab Grade Polypropylene Casework Standard."

PLEASE NOTE ON NOVEMBER 7, 2025 AT SEFA'S ANNUAL CONFERENCE THE MEMBERSHIP UNANIMOUSLY APPROVED CHANGING THE NAME OF THIS DOCUMENT FROM "SEFA RECOMMENDED PRACTICES" TO "SEFA STANDARD."

Note : *Testing as described in this document must be performed and documented by a SEFA-approved third party testing facility. Visit SEFALABS.COM for the most current list of SEFA-approved test labs.*

SEFA Glossary of Terms

SEFA has developed a Glossary of Terms (SEFA 4-2020) for the purpose of promoting a greater understanding between designers, architects, manufacturers, purchasers and end users. The terms defined by SEFA are frequently used in contracts and other documents, which attempt to define the products to be furnished or the work involved. The Association has approved this Glossary in an effort to provide uniformity among those who use these terms. Where a specific Standard contains definitions which differ from those in the Glossary of Terms, then the definitions in the specific Standard should be used.

SEFA encourages all interested parties to submit additional terms or to suggest any changes to those terms already defined by the Association. The definitions should be used to help resolve any disputes that may arise or to incorporate the applicable terms in any contract or related documents.

SEFA Disclaimer

SEFA uses its best effort to promulgate Standards for the benefit of the public in light of available information and accepted industry practices. SEFA does not guarantee, certify or assure the safety or performance of any products, components, or systems tested, installed, or operated in accordance with SEFA Standards or that any tests conducted under its Standards will be non-hazardous or free from risk. SEFA encourages the use of third party independent testing where appropriate.

1.0 Scope

The scope of this document is intended to provide manufactures, specifiers, and users tools for evaluating the safety, durability, and structural integrity of polypropylene laboratory grade furniture and complimentary items. This document is inclusive of casework (base units, wall mounted units, counter mounted units, mobile base cabinets, tall units) tables and shelving systems. Casework, tables, and shelving manufactured for laboratory use should be subjected to the tests and procedures outlined below.

Polypropylene laboratory grade casework shall consist of base cabinets, wall cabinets, counter mounted cabinets, tall cabinets, tables, and shelving.

Aggregate test results may vary by manufacturer. Procedures for testing performance criteria shall be as outlined in this document and results made available upon request. It is assumed that the test model reflects the performance criteria for all products. However there may be certain door/drawer configurations and/or sizes outside the test unit configuration identified that may not meet certain parts of this test. A test unit has been identified in this document with the sole purpose of obtaining continuity of procedures and results in a scientific format.

Great care should be exercised when heavy loads are applied to the cabinet and appropriate safety precautions taken to insure safety of testing personnel. Properly trained personnel should perform all tests. SEFA assumes no liability for damage or injury as a result of conducting these tests.

The acceptance levels are based on the cumulative field experience and laboratory testing of SEFA members based on actual needs of laboratories. This is a performance-based document. Specifications proscribing specific materials, hardware, finishes, workmanship or construction may or may not meet acceptance levels of this document. If proscriptive components of the specifications conflict with compliance of this document then the Architectural proscribed elements take precedent.

Testing as outlined in this document must be performed and documented by a SEFA-approved independent third party testing facility.

2.0 Purpose

The purpose of this document is to describe the distinguishing performance characteristics of laboratory grade polypropylene furniture and complimentary items. Furniture shall be of a type specifically designed and manufactured for installation and use in a laboratory.

Although aggregate test results may vary from manufacturer to manufacturer, procedures for testing performance criteria shall be as outlined in this document and results made available upon request. It is assumed that the test model reflects the performance criteria for all products regardless of construction, size, or style used. A test unit has been identified in this document with the sole purpose of obtaining continuity for procedures and results in a scientific format.

3.0 Definitions

Acceptance Levels - The acceptance level for each performance criteria is based on the cumulative experience of actual field testing and laboratory results of SEFA members. Acceptance levels describe the expected outcome of each test procedure.

ANSI/BIFMA - ANSI is the American National Standards Institute. Approval of an American National Standard requires verification by ANSI that the requirements for due process, consensus, and other criteria for approval have been met by the standards developer. BIFMA is the Business and Institutional Furniture Manufacturer's Association, an association of manufacturers of desk products and the like.

Apparatus - A machine or group of machines and accessories.

Arithmetic Mean - A number obtained by dividing the sum of a set of quantities by the number of quantities in a set; average.

ASTM - American Society for Testing and Materials.

Base Cabinets - A base cabinet is a storage device consisting of two ends, a back, a face and may or may not include a top or top frame. The face may be open, to access the storage area, or may be outfitted with one or more drawers and/or doors. A base cabinet is always placed on the floor and normally supports a surface. The top surface is normally no more than 42" (1,067mm) off the floor surface.

Best Practices - When given a choice of grade, the "best practice" is to select one that offers a well defined degree of control over the quality of workmanship, materials, and installation of a project. SEFA-8 Recommended Practices are written from a view of high quality laboratory furniture.

Cabinet Depth (Deep) - Given a front, bottom, two sides, and a top, the cabinet depth is a measure of the side of the cabinet, in its normal upright position, from the outside back to the outside front excluding doors and door fronts.

Cabinet Height (High) - Given a front, bottom, two sides, and a top, the cabinet height is a measure of the side of the cabinet, in its normal upright position, from the bottom edge of the side to the top, excluding any surface.

Cabinet Width (Wide) - Given a front, bottom, two sides, and a top, the cabinet width is a measure of the front of the cabinet in its normal upright position from one side to the other.

Casework - Base and wall cabinets, display fixtures, and storage shelves. The generic term for both "boxes" and special desks, reception counters, nurses stations and the like. Generally includes the tops and work surfaces.

Caster - A small wheel on a swivel, set under a piece of furniture, a machine, etc., to facilitate moving it.

Chase (Plumbing Area) - Space located behind the back of the base cabinet used to house plumbing or electric lines.

Combination Unit - A base unit of the type that has both door(s) and drawer(s).

Counterbalance - A device or weight incorporated into the cabinet body to prevent overturning when movable elements are extended.

Counter Mounted Cabinet - A counter mounted cabinet is a wall cabinet (usually with a height of approximately 48" [1,219mm] and is typically mounted on the work surface or shelf, as in a reagent shelf).

Cupboard (Door Unit) - That portion of the cabinet with no drawer(s) that may be enclosed by doors.

Drawer - A sliding storage box or receptacle opened by pulling out and closed by pushing in.

Free Standing - Requiring no support or fastening to other structures.

Hardware - Items such as screws, pulls, hinges, latches, locks, and drawer slides used in the construction of casework.

Interlocking Hardware - A device that limits drawer and/or pull-out shelf movement to only one at a time.

Joinery - The junction of two pieces intended to be permanently connected.

Laboratory Cart - A platform or multiple platforms with 4 wheels or casters designed and used to transport chemicals and/or instruments in laboratory and education settings (Currently not tested by SEFA).

Laboratory Furniture - Furniture designed and manufactured for installation and use in a laboratory.

Latch - A piece of hardware designed to hold a door closed.

Leveling Screws (Levelers) - Threaded components designed to allow adjustment of the cabinet vertically as needed for leveling.

Mobile Base Cabinet - A free standing storage cabinet mounted on casters specifically designed to be housed below an adjustable height bench/table and for movement within the room or space for optimal reconfiguration and flexibility and not to be used for transporting chemicals or instruments.

Mobile Tall Cabinet - A free standing storage cabinet mounted on casters and capable of being readily moved or relocated. Mobile storage tall cabinets are designed for movement within a room or space for reconfiguration and flexibility and not to be used for transporting chemicals or instruments. (Currently not tested by SEFA)

Movable Element - An element that can be moved to protrude past the cabinet body, including but not limited to doors, drawers and pull-out shelves.

Nominal Dimensions - Not all cabinet manufacturers produce product to the identical dimensions. All dimensions given in this document are accurate to within five percent, which is considered nominal.

Permanent Damage - Destruction to material or joinery that would require repair in order to return to its original state.

Permanent Deformation - Deflection that has exceeded the limits of the product, thus changing the original shape of the product

Permanent Deterioration - Erosion or corrosion of material such that the component will never return to its original shape.

Permanent Failure - See "permanent damage."

Pulls - Articles of hardware used to grasp and open/close the door or drawer (see also hardware).

Rack Resistance - The ability of a product to resist stresses that tend to make the product distort and the drawers to become misaligned.

Rail - A horizontal member extending from one side of the cabinet to the other.

Reagent - A substance used because of its chemical or biological activity.

Removable Back - A panel located on the inside back of the base cabinet, which is removable in order to gain access to utilities.

Submersion - Covered with water.

Tables - An article of furniture having a flat, horizontal surface supported by one or more support members (legs), and a frame (apron).

Tall Cabinet (Full Height Unit) - A tall cabinet is a storage device that consists of two ends, a top and bottom panel, a back and a face. The face may be open to access the storage area or may be outfitted with one or more drawers and/or door(s). A tall cabinet is always placed on the floor and is nominally 84" (2,134mm) high.

Torsion - A force acting at a distance which tends to twist or rotate an object or cabinet.

Uniformly Distributed - A force applied evenly over the area of a surface.

Unobstructed Entry - A cabinet is deemed to be unobstructed if access to the entire storage area is completely without obstacle.

Upright Position - A cabinet oriented in its intended position.

Wall Cabinet - A wall cabinet is a storage device consisting of two ends, a back, a top, bottom, and a face. The face may be open to access the storage area or may be outfitted with one or more door(s). The wall cabinet usually does not include a drawer. A wall cabinet is always mounted on a vertical surface such as a wall, a divider, panel or some other vertical structure. A wall cabinet is usually less than 48" (1,219mm) high.

Work Surface - A normally horizontal surface used to support apparatus at a convenient height above the floor. Work surfaces are normally positioned atop a base cabinet or table structure.

3.1 Description of Testing Apparatus

Solid Steel Bar - A square solid steel bar 2 1/2" (63mm) square, 28 1/4" (717mm) long, weighing

50 pounds (22.679 Kg).

Sand or Shot Bag (10 pounds [4.545 Kg]) - A bag of plastic or cloth with the approximate dimensions 10 9/16" (268mm) x 11" (279mm) as in typical "gallon size re-closable stor-age bags." Filled with enough sand or shot so that contents weigh 10 pounds (4.545 Kg).

Sand Bag (20 pounds [9.071 Kg]) - Two 10 pound (4.545 Kg) sand bags bound together.

Shot Bag (100 lbs. [45.359 Kg]) - A plastic or cloth bag of sufficient size to contain 100 pounds (45.359 Kg) of shot.

Cycling Mechanism - Per ANSI BHMA 156.9.-2003

Steel Rod - A 2" (51mm) diameter by 12" (305mm) long rod, approximately 10 pounds (4.535 Kg) in weight.

Hot Water - To be considered "hot water," the temperature of the water must be between 190° F to 205° F (88° C to 96° C).

One Pound Ball - Solid steel sphere approximately 2" (51mm) in diameter.

Hardwood Corner Block - A block of hardwood 2" (51mm) square by 1" (25.4mm) high.

Threshold – A ½" High x 4" Wide x 36" Long rectangular block with a ½" High x 1" Deep Bevel along each length. Material selected shall be substantial and not move or deform during the test, such as hardwood or poly.

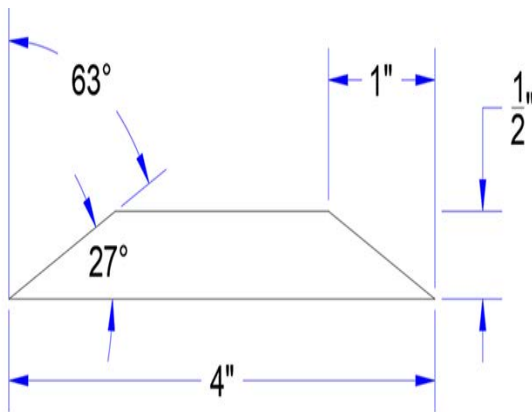

4.0 Base Cabinets

4.1 Description of Test Cabinet

The base cabinet shall be a combination of doors and drawers per Figure 1. The base cabinet shall have nominal dimensions of 48" (1,219.2mm) wide, 36" (914.4mm) high, and 22" (558.8mm) deep. The drawers shall be above the doors, half width and approximately one-fourth the height of the cabinet's face opening. The cabinet back shall be the removable type (per manufactures' standard design as used for access to the plumbing or chase area) with the removable panel removed.

The cabinet shall be free standing, squared and leveled. For purposes of testing, the cabinet shall be squared and leveled and sitting 1" (25.4mm) off the floor atop four hardwood corner blocks 2" (50.8mm) square and 1" (25.4mm) high. A top of 1" (25.4mm) thick 37-50 pcf medium density fiberboard shall be positioned on the cabinet without glue or fasteners of any kind. The top dimensions will be such that it will overhang the cabinet perimeter by 1" (25.4mm). Its weight shall be included in the test as live load. Before conducting the test, a visual examination shall be conducted to verify that the unit configuration and setup conditions are appropriate. Operate doors and drawer. Doors should be free moving and latch properly. Inspect the unit for dimensions and note the fit of doors and drawers to the cabinet body. Open and close the drawer. The drawer should be free moving and function as specified by the manufacturer. Discontinue evaluation if unit is not in compliance or if malfunction is noted.

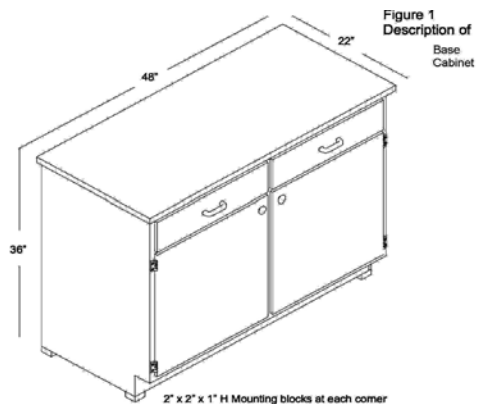

4.2 Cabinet Load Test -

4.2.1 Purpose of Test

The cabinet load test will challenge the structural integrity and load bearing capability of the cabinet construction. This test will demonstrate the ability of the cabinet to support heavy applied loads. This is not intended to test the functional characteristics of the cabinet under heavy loads.

4.2.2 Test Procedure

Verify that the cabinet is level. Remove drawer and open doors for testing purpose. Load the cabinet top by using 1600 pounds (725.755 Kg) of solid steel bars (per Section 3.1) stacked in an evenly distributed manner across the entire top surface, per Figure 2. After ten minutes unload the cabinet.

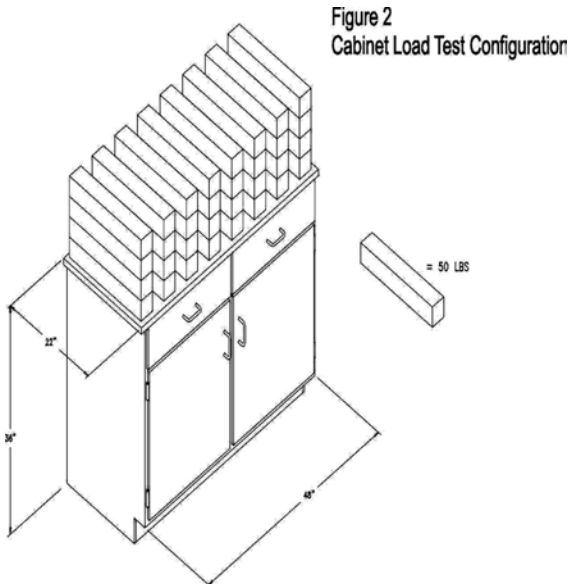

4.2.3 Acceptance Level

The cabinet will have no permanent failure.

4.3 Cabinet Concentrated Load Test

4.3.1 Purpose of Test

The purpose of this test is to challenge the functional characteristics of the cabinet when subjected to a concentrated load on the center of the cabinet top.

4.3.2 Test Procedure

Using solid weights or 10 pound (4.535 Kg) sand bags (per Section 3.1), apply a total of 160 pounds (72.576 Kg) to the top of the cabinet along the cabinet centerline (see Figure 3). Operate doors and drawers.

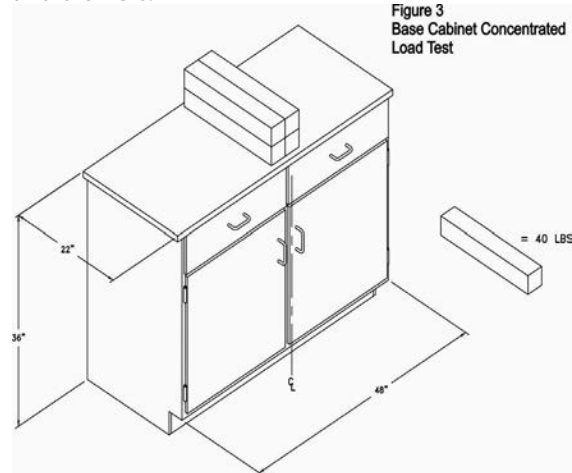

4.3.3 Acceptance Level

Under condition of test load, doors and drawers shall operate normally. There shall be no permanent distortion to front rail, cabinet joinery, doors or drawers.

4.4 Cabinet Torsion

4.4.1 Purpose of Test

This test will evaluate the structural integrity of the cabinet construction when subjected to a torsional load.

4.4.2 Test Procedure

The cabinet shall be tested in its normal upright position, raised not less than four-inches off the floor and supported on rear and one front corner. The area of support under the cabinet shall be located not more than 6" (152.4 mm) in from each supported corner. Secure the cabinet diagonally from the unsupported corner with solid steel bars or sand bags per Section 3.1, 280 pounds (127.27 Kg) of weight on the top of the cabinet to prevent overturning. Apply solid weights or sand bags to achieve 160 pounds of weight [72.73 Kg] to the unsupported corner for a period of fifteen

minutes (see: Figure 4). Remove weight and place cabinet on the floor in its normal upright position. Observe cabinet joinery. Level the cabinet and measure the face and back of the cabinet across the diagonal corners.

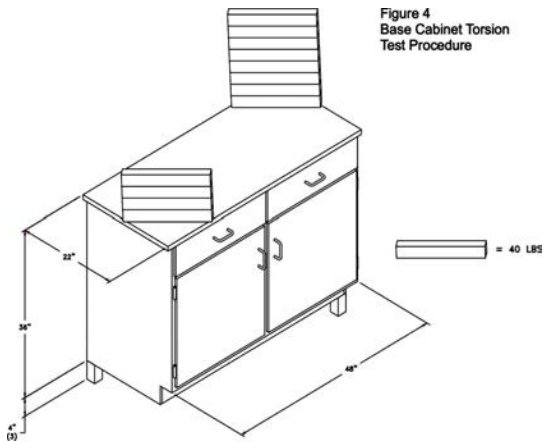

4.4.3 Acceptance Level

When returned to normal position, the operation of the cabinet shall be normal, and there will be no permanent damage. The difference between the two measurements taken from measuring the diagonal corners shall be no more than 1/8" (3.175mm).

4.5 Cabinet Submersion Test

4.5.1 Purpose of Test

This test will demonstrate the ability of a cabinet to resist wicking of moisture from the floor. Only units that rest on the floor or a unit where the base is within 2" (50.8mm) of the floor should be subjected to this test.

4.5.2 Test Procedure

The material thickness along the perimeter of the cabinet shall be measured on 6" (152.4mm) increments. Record the thickness of the material to be submerged in water. Calculate the arithmetic mean of the data taken. Place the entire test cabinet in its upright position such that the cabinet is submerged in a deep pan so that the cabinet is in 24" (609.6mm) of water. After four hours, remove the unit from the water and immediately measure the thickness of the material

at the same points measured initially. Calculate the new arithmetic mean. After the unit has been allowed to dry, inspect for other damage.

4.5.3 Acceptance Level

The cabinet will show no permanent deformation or deterioration. Increase in thickness shall not exceed four percent of the initial mean measurements.

4.6 Spill Containment Test

4.6.1 Purpose of Test

This test will demonstrate the ability of a cabinet to hold standing water. Any polypropylene cabinet, be it floor mounted, wall case, or under counter mount, should have the ability to hold said water, for an infinite amount of time.

4.6.2 Test Procedure

The cabinet shall be tested in its normal upright position, raised not less than four-inches off the floor, and supported level. The supports should be stationed away from all weld seam areas, on the underside. Fill cabinet with water, engulfing whole bottom, to within 1/8" of top, of bottom rail. Let stand for one hour. Inspect for water droplets, if droplets found, mark area on cabinet, with colored tape, grind out weld, re-weld, and repeat procedure.

4.6.3 Acceptance Level

The cabinet will show no signs of leakage, and have no gaps, or voids in weld seams. The cabinet will show no signs of permanent deformation or deterioration.

5.0 Doors

5.1 Door Hinge Test

5.1.1 Purpose of Test

This test will demonstrate the durability of the door and its hardware (hinge leaf, screws, etc.) to an applied load of 120 pounds (54.43 Kg).

5.1.2 Test Procedure

With unit and top set as described in Section 4.1, add sufficient weight to the top in order to prevent overturning. With cabinet door opened 90-degrees, hang a sling made up of sand bags of 120 pounds (54.43 Kg) weight over top of the door at a point 12" (304.8mm) out from the hinge centerline (see Figure 5). Slowly move door through the full cycle of the hinge, up to a 160-degree arc. Remove weight and swing door through its full intended range of motion and close door.

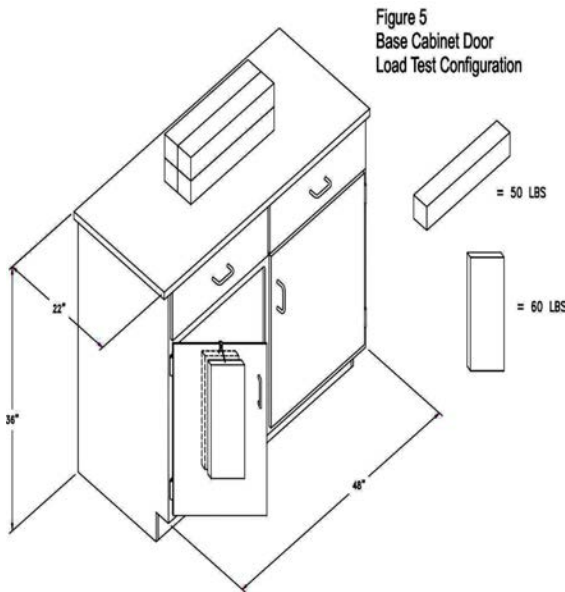

5.1.3 Acceptance Level

The open door shall withstand a load of 120 pounds (54.43 Kg) when applied at a point 12" (304.8mm) from the hinge centerline without significant permanent distortion. Operation of the door, after test, shall show no significant permanent distortion that will cause binding of the door or hinges or that will adversely affect operation of the catch.

5.2 Door Impact Test

5.2.1 Purpose of Test

This test will demonstrate the resistance of a 190 inch-pound impact to the door face. Only units that extend below the work surface should be subjected to this test. This test should not be inclusive of glass doors.

5.2.2 Test Procedure

With unit and top set as described in Section 4.1, add sufficient weight to the top in order to prevent overturning. A 10 pound (4.534 Kg) sand bag (per Section 3.1) shall be suspended and dropped to provide an impact of 190 inch-pounds at the center of the closed door (see Figure 6).

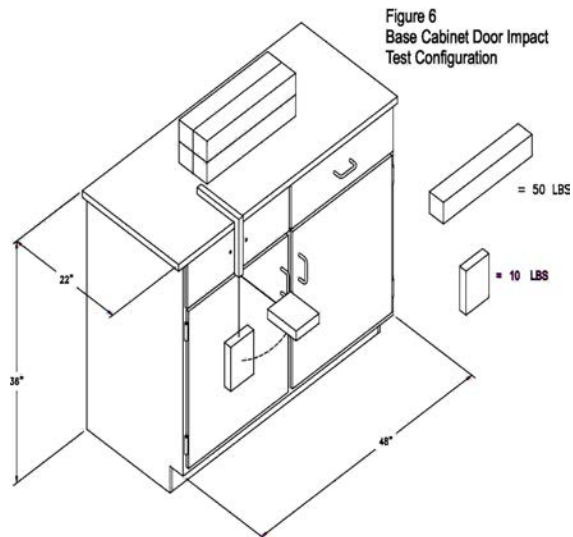

5.2.3 Acceptance Level

After the test, the door and catch shall operate normally and show no permanent damage.

5.3 Door Cycle Test

5.3.1 Purpose of Test

This test will demonstrate the durability of the door hinge hardware to withstand 50,000 cycles as a reliable measure for longevity.

5.3.2 Test Procedure

This test shall be in conformance to the ANSI test procedure A156.9, Grade 1, requirements for cycle testing of doors. A cycling mechanism shall swing door 90-degrees. Door shall operate for 50,000 cycles with a speed not greater than 8 cycles per minute.

5.3.3 Acceptance Level

Door shall operate for the full cycle period without deterioration that will significantly affect the function of the door. The door shall operate freely without binding.

6.0 Drawers

6.1 Drawer Static Test

6.1.1 Purpose of Test

This test will demonstrate the ability to support a point load given to the front of the drawer and will challenge the attachment of the drawer head to the drawer.

6.1.2 Test Procedure

With unit and top set as described in Section 4.1, add sufficient weight to the top in order to prevent overturning. Open the drawer to 13" (330.2mm) of travel and hang 120 pounds (54.43 Kg) from the drawer head at the centerline of the drawer for five minutes (see Figure 7). Remove the weight and operate the drawer through the full cycle.

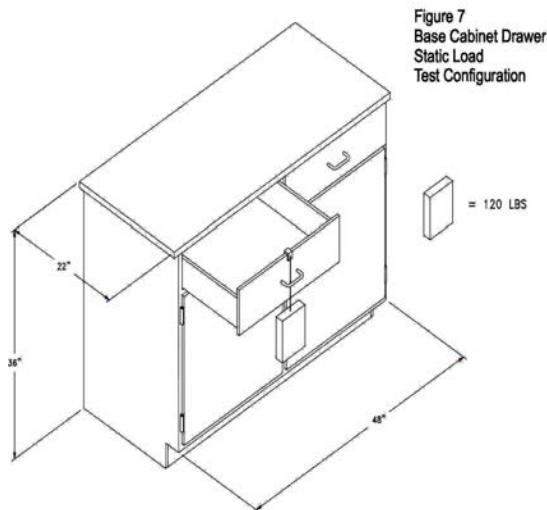

6.1.3 Acceptance Level

There shall be no interference with the normal operation of the drawer.

6.2 Drawer and Door Pull Test

6.2.1 Purpose of Test

This test will evaluate the strength of the pull and pull hardware.

6.2.2 Test Procedure

Pulls are to be installed in accordance with manufacturer's practice using specified attaching hardware and method. Block door and drawer closed. Using a cable, pulley and weight assembly (see Figure 8), apply a force of 40 pounds (18.144 Kg) perpendicular to each pull. Revise setup to hang weight from each pull (see Figure 9). Remove weight.

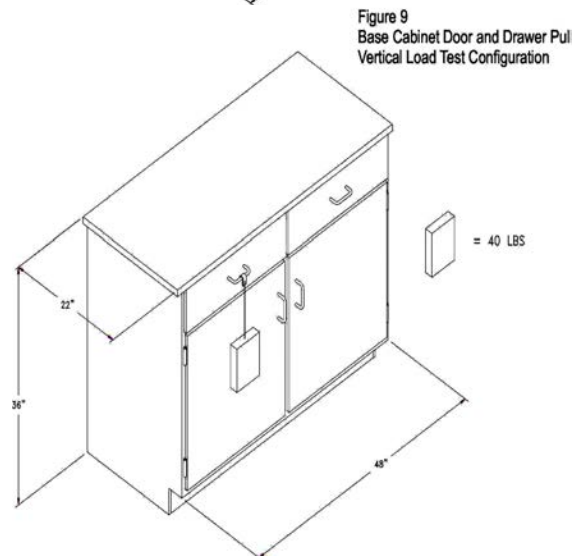
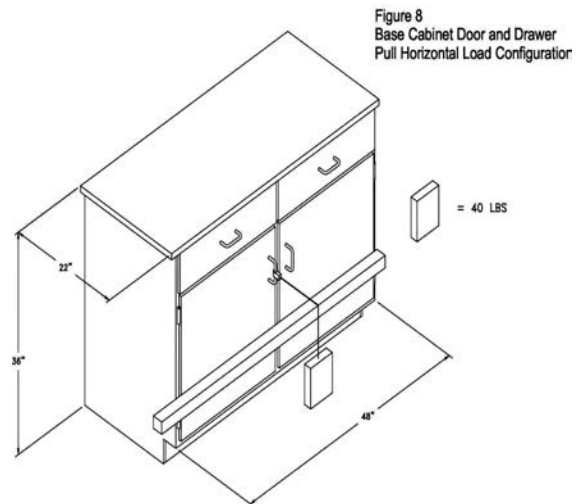

6.2.3 Acceptance Level

Pulls shall resist force and support weight without breakage. After completion of test and removal of weight, there shall be no significant permanent distortion. Some pull designs will require variations to set up apparatus. These pulls shall be tested in conformance to the applied pull forces.

6.3 Drawer Impact Test

6.3.1 Purpose of Test

This test will demonstrate the resistance to impact of the drawer bottom and slide mechanism.

6.3.2 Test Procedure

Open drawer to 13" (330.2mm) of travel. Drop an 8 pound (3.629 Kg) sand or shot bag from a height of 24" (609.6mm) into the bottom of a drawer at the center of the width of the drawer and 6" (152.4mm) back from the inside face of the drawer. Remove the sand or shot bag.

6.3.3 Acceptance Level

Operate drawer through full cycle. Drawer shall operate normally. Any deformation will not cause binding or interfere with the operation of the drawer.

6.4 Drawer Internal Rolling Impact Test

6.4.1 Purpose of Test

This test will evaluate the strength of the drawer head, bottom, and back as a result of opening and closing the drawer with a rolling load.

6.4.2 Test Procedure

Position the drawer on a table at a 45-degree angle per Figure 10. Place a 2" (50.8mm) diameter by 12" (304.8mm) long steel rod (approximately 10 pounds [4.536Kg]) 13" (330.2mm) from the target impact area such that the rod will roll freely to impact the back of the drawer. Subject the back to three impacts and reverse the drawer to subject the front to three additional impacts.

Figure 10
Base Cabinet Drawer Internal
Rolling Impact
Test Configuration

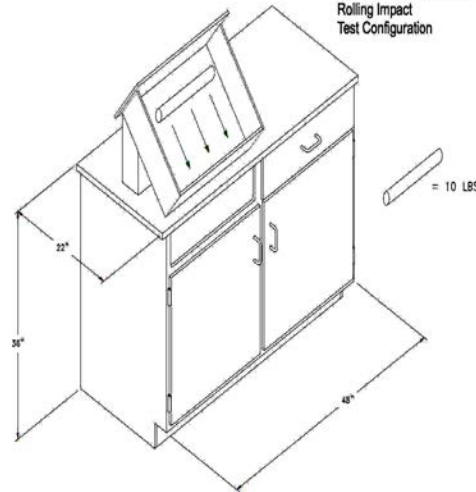

6.4.3 Acceptance Level

The drawer shall show no permanent damage. All joinery shall be intact and the drawer, when replaced in the unit, shall operate normally. Minor scratches and dents are acceptable.

6.5 Drawer Cycle Test

6.5.1 Purpose of Test

This test is intended to replicate years of operation of a drawer under a load.

6.5.2 Test Procedure

Laboratory Load (10 pounds [4.535 Kg]) - A static load of 10 pounds (4.535 Kg) (using a ten 10 pound [4.359 Kg] sand bag per Section 3.1) shall be uniformly distributed in the drawer. Measure force required to activate the drawer. Operate from a closed position to within 1/4" (6.35mm) of full extension for 25,000 cycles at a rate not to exceed 4 cycles per minute.

6.5.3 Acceptance Level

The drawer shall operate freely without evidence of dragging rubbing or binding. The force required to open and close loaded drawer shall not be more than a 20% increase of that required prior to test and shall not be greater than 8 pounds (3.487 Kg) to activate hardware.*

Note: *The American's with Disabilities Act (ADA) requires a force no greater than five pounds to activate hardware. The load rating in this document is intended only for testing conditions where loads challenge the durability of the hardware. Under actual conditions, drawer loading should be reduced to levels that result in compliance with ADA as applicable.

7.0 Shelving

7.1 Description of Test Unit

Shelves shall be tested using the following procedure. This is inclusive of shelves in wall cabinets, counter mounted cabinets, full height cabinets, wall mounted shelves and free standing shelves. Typical thicknesses are 1/2" for most applications. Shelves to have lips on at least two sides. Other factors that should be evaluated when selecting shelving include chemical resistance, impact resistance, color and appearance, abrasion resistance, cost, and support requirements. Consult with the manufacturer for assistance with these other criteria.

7.2 Shelf Load Test

7.2.1 Purpose of Test

This test will demonstrate the ability of a shelf and its mounting hardware to support normal laboratory loads.

7.2.2 Test Procedure

A shelf shall be mounted in the manner in which it is designed. Measure the distance from the underside of the shelf to a reference point perpendicular to the center of the shelf. Use sand bags weighing 10 pounds (4.545 Kg) each. Unless otherwise specified, load the shelf uniformly to 10 pounds (4.545 Kg) per square foot shelf area to a maximum of 75 pounds (30.01 Kg). Measure the deflection on the shelf by measuring the distance to the reference point and calculating the difference between the two measurements. Record data and remove load from the shelf.

7.2.3 Acceptance Level

Longer shelves will support less loads than shorter

shelves. The allowable maximum deflection of a shelf is 1/180 of the span and not in excess of .25" (6.35mm). The following formula may be used to calculate the approximate deflection expected from a uniformly distributed load:

$$D (\text{max.}) = 5W L^3 / 384 E I$$

Where:

D = Deflection in inches (Maximum 1/180 span, not to exceed .25" (6.35mm).

W = (Design Load) x (Shelf Depth in Inches) x (Shelf Span in Inches)

(Design Load = 10 pounds / square foot divided by 144)

L = Span between supports in inches

E = Modulus of Elasticity per ASTM D790 (Polypropylene = 185,000)

I = Cross section moment of inertia
 $(I = b \times h^3 / 12)$ (Shelf Depth in Inches x Shelf Thickness in Inches cubed) / 12.

POLYPROPYLENE EXAMPLE:

Assuming Shelf is 1/2" thick x 20" deep x 48" wide but with support in middle of shelf (L = 24")

$$\text{Design Load} = 10 \text{ pounds} / 144 = .07$$

$$L = 24"$$

$$I = (20") \times (.5")^3 / 12 = .21$$

$$\text{Solve for } W = (.07) \times (20") \times (24") = 33.6$$

$$D (\text{max.}) = 5 (33.6) (24^3) / 384 (185,000) (.21) = 2,322,432 / 14,918,400 = .15" \text{ Deflection}$$

NOTE: Polypropylene shelves typically have welded lips, stiffeners, and/or cross members, depending on manufacturer. Any such thickness enhancers act to increase Moment of Inertia (I) and thereby decrease D (max.) deflection or allow for higher shelf loads. Above calculations are without any added stiffeners.

8.0 Cabinet Surface Finish Tests

8.1 Chemical Spot Test

Users should consider the chemical and staining agents that might be used near the laboratory casework. Common guidelines can be found by referring to: The casework manufacturer printed data for chemical and stain resistance. Because chemical and stain resistance is affected by concentration, time, temperature, humidity, housekeeping and other factors, it is recommended that users test samples in their actual environment with the substances they use.

8.1.1 Purpose of Test

The purpose of the chemical spot test is to evaluate the resistance a finish has to chemical spills.

Note: Many organic solvents are suspected carcinogens, toxic and/or flammable. Great care should be exercised to protect personnel and the environment from exposure to harmful levels of these materials.

8.1.2 Test Procedure

Obtain one sample panel measuring 14" x 24" (355.6mm x 609.6mm). The received sample to be tested for chemical resistance as described herein. Place panel on a flat surface, clean with soap and water and blot dry. Condition the panel for 48-hours at 73° +/- 3°F (23° +/- 2°C) and 50 +/- 5% relative humidity or the currently accepted guideline set by ASTM. Test the panel for chemical resistance using forty-nine different chemical reagents by one of the following methods.

Method A - Test volatile chemicals by placing a cotton ball saturated with reagent in the mouth of a 1-oz. (29.574cc) bottle and inverting the bottle on the surface of the panel.

Method B - Test non-volatile chemicals by placing five drops of the reagent on the surface of the panel and covering with a 24mm watch glass, convex side down.

For both of the above methods, leave the reagents on the panel for a period of one hour. Wash off the panel with water, clean with detergent and naphtha, and rinse with deionized water. Dry with a towel and evaluate after 24-hours at 73° +/- 3°F (23° +/- 2°C) and 50 +/- 5% relative humidity, or the currently accepted guideline set by ASTM using the following rating system.

Level 0 - No detectable change.

Level 1 - Slight change in color or gloss.

Level 2 - Slight surface etching or severe staining.

Level 3 - Pitting, cratering, swelling, or erosion of coating. Obvious and significant deterioration.

Note: Percentages are by volume.

8.1.3 Acceptance Level

Range of results is provided to establish the acceptable range for a Laboratory Grade Finish. Results will vary from manufacturer to manufacturer due to differences in finish formulations. Laboratory grade finishes shall result in no Level 3 conditions. Individual test results, for the specified 49 reagents, will be verified with the established third party, independent SEFA 8 test submittal form. Suitability for a given application is dependent upon the chemicals used in a given laboratory.

Test No.	Chemical Reagent	Test Method
1.	Acetate, Amyl	A
2.	Acetate, Ethyl	A
3.	Acetic Acid, 98%	B
4.	Acetone	A
5.	Acid Dichromate, 5%	B
6.	Alcohol, Butyl	A
7.	Alcohol, Ethyl	A
8.	Alcohol, Methyl	A
9.	Ammonium Hydroxide, 28%	B
10.	Benzene*	A
11.	Carbon Tetrachloride	A
12.	Chloroform	A
13.	Chromic Acid, 60%	B
14.	Cresol	A
15.	Dichloroacetic Acid	A
16.	Dimethylformamide	A
17.	Dioxane	A
18.	Ethyl Ether	A
19.	Formaldehyde, 37%	A
20.	Formic Acid, 90%	B
21.	Furfural	A
22.	Gasoline	A
23.	Hydrochloric Acid, 37%	B
24.	Hydrofluoric Acid, 48%	B
25.	Hydrogen Peroxide, 30%	B
26.	Iodine, Tincture of	B
27.	Methyl Ethyl Ketone	A
28.	Methylene Chloride	A
29.	Monochlorobenzene*	A
30.	Naphthalene	A
31.	Nitric Acid, 20%	B
32.	Nitric Acid, 30%	B
33.	Nitric Acid, 70%	B
34.	Phenol, 90%	A
35.	Phosphoric Acid, 85%	B
36.	Silver Nitrate, Saturated	B
37.	Sodium Hydroxide, 10%	B
38.	Sodium Hydroxide, 20%	B
39.	Sodium Hydroxide, 40%	B
40.	Sodium Hydroxide Flake	B
41.	Sodium Sulfide Saturated	B
42.	Sulfuric Acid, 33%	B
43.	Sulfuric Acid, 77%	B
44.	Sulfuric Acid 96%	B
45.	Sulfuric Acid, 77% & Nitric Acid, 70% equal parts	B
46.	Toluene	A
47.	Trichloroethylene	A
48.	Xylene	A
49.	Zinc Chloride, Saturated	B
*If the use of this chemical is permitted by law in the country where the testing is being performed.		

8.1.4 Additional Chemical Resistance Data for Polypropylene (PP) and Fire-Retardant Polypropylene (FRPP - UL 94 V/O Grade)

The following data is made available from several manufacturers of polypropylene extruded sheet, which is used in the manufacture of polypropylene casework and fume hoods. Polypropylene casework and hood manufacturers do not alter the chemical resistance of original raw extruded sheet when manufacturing their casework and hoods, and other polypropylene furniture. No coatings, laminates, or any other changes to raw stock are made before and during the manufacturing of polypropylene furniture. Therefore chemical resistance data as provided by the raw sheet manufacturers should be no different than resistance data of finished furniture.

The test protocols range in detail between raw sheet manufacturers but none are less stringent than above chemical contact test described in Section 8.1.2. Many immerse polypropylene samples in chemicals for several hours and even days.

The following is a more extensive list of chemicals which are compatible with polypropylene. These are provided to offer specifiers greater chemical compatibility information for most commonly used chemicals.

The following data describes the highest temperature (F) of the particular chemical for which polypropylene is recommended (R), without significant adverse effect (No Level "3"s). Because elevated temperatures of many chemicals increase their corrosive effect on materials (some dramatically), it is important to include this temperature data for more meaningful information purposes.

Chemical Resistance Chart Disclaimer

The data in the following tables were obtained from numerous polypropylene resin manufacturers in the industry. The information is based primarily on the immersion or spot testing of unstressed sample strips or wafers in the chemicals listed at ambient and elevated

temperatures and, to a lesser degree, on filed experience with various products. The end user should be aware of the fact that the actual service conditions will affect the chemical resistance. The chemical resistance table should be used for a reference guide. It is the ultimate responsibility of the end user to determine the compatibility or suitability of the chemicals and materials being used in their particular application.

R = Recommended up to temperature indicated

NR = Not Recommended

Chemical Concentrations	PP	FRPP
Acetic Acid 5%	R-200F	R-200F
Acetic Acid 10%	R-200F	R-200F
Acetic Acid 50%	R-185F	R-185F
Acetic Acid 80%	R-120F	R-120F
Alcohol	R-120F	
Alcohols-		
Amyl	R-170F	
Butyl	R-180F	
Ethyl	R-100F	R-100F
Isobutyl	R-140F	
Isopropyl	R-150F	
Methyl	R-150F	R-150F
Propyl	R-73F	R-73F
Alum	R-180F	
Aluminum Hydroxide	R-180F	
Aluminum Phosphate	NR	
Aluminum Sulfate	R-180F	
Ammonia, Anhydrous	NR	
Ammonia, Liquid	R-108F	
Ammonia, Nitrate	R-180F	
Ammonia, Chloride	R-170F	
Ammonium, Fluoride 10%	R-180F	R-180F
Ammonium, Fluoride 20%	R-180F	R-180F
Ammonium, Fluoride 25%	R-73F	R-73F
Ammonium, Hydroxide	R-180F	
Ammonium, Nitrate	R-180F	
Ammonium, Persulfate	R-180F	
Ammonium, Salts	R-180F	
Ammonium, Sulfate	R-180F	
Anti-Freeze	R-180F	
Antimony Chloride	R-140F	
Aqua Regia	NR	
Bleach	R-73F	
Boric Acid	R-180F	
Brine	R-140F	
Bromic Acid	R-140F	
Bromine Gas	NR	
Bromine Liquid	NR	
Bromine Water	NR	
Butyl Carbitol		
Butyl Cellosolve		
Calcium Carbonate	R-180F	
Calcium Chlorate	R-180F	
Calcium Chloride	R-180F	
Calcium Dioxide		

Chemical Concentrations	PP	FRPP
Carbonic Acid	R-140F	
Caustic Lime	R-180F	
Caustic Potash	R-180F	
Caustic Soda	R-180F	
Cellosolve		
Chlorine Gas, Wet	NR	
Chlorine, Liquid	NR	
Chlorine Water	NR	
Clorox Bleach 5.5%	NR	
Chromic Acid 5%	R-140F	R-140F
Chromic Acid 10%	R-140F	R-140F
Chromic Acid 20%	NR	R-72F may cause cracking under stress
Chromic Acid 30%	NR	R-72F may cause cracking under stress
Chromic Acid 60%		
Copper Cyanide	R-180F	
Copper Sulfate	R-180F	
Copper Sulfate 5%		
Corn Oil	R-100F	
Corn Syrup	R-150F	
Cottonseed Oil	R-150F	R-150F
Cupric Nitrate	R-180F	
Cupric Salts	R-180F	
Cupric Sulfate	R-180F	
Cyclohexanone	R-68F	
Detergents	R-140F	R-140F
Dichlor Acid 60%		
Dichromate Acid 5%		
Dimethylformamide		
Dioxane		
Disodium Phosphate	R-180F	
Ethanol	R-100F	
Ethyl Acetate	R-68F	NR
Ethyl Ether	R-68F	
Ferric Chloride Anhydrous	R-73F	
Ferric Nitrate	R-180F	
Ferric Sulfate	R-180F	
Fluorboric Acid	R-140F	
Fluosilicic Acid 25%	R-140F	
Formaldehyde	R-104F	R-104F
Formaldehyde 35%	R-140F	R-140F
Formaldehyde 50%	R-73F	R-73F
Formaldehyde 50%	R-73F	R-73F
Freon 11	R-73F	
Furfural		

Chemical Concentrations	PP	FRPP
Fuel Oil	R-73F	
Gasoline		
Glycerin	R-180F	
Hydrochloric Acid		
Hydrochloric Acid 10%	R-160F	R-160F
Hydrochloric Acid 20%	R-160F	R-160F
Hydrochloric Acid 25%	R-160F	R-160F
Hydrochloric Acid 37%	R-160F	
Hydrocyanic Acid	R-140F	
Hydrocyanic Acid 10%	R-140F	
Hydrofluoric Acid 10%	R-140F	R-140F
Hydrofluoric Acid 20%	R-140F	R-140F
Hydrofluoric Acid 30%	R-140F	R-140F very slight discoloration
Hydrofluoric Acid 40%	R-140F	
Hydrofluoric Acid 50%	R-73F	
Hydrofluoric Acid 65%	R-73F	
Hydrofluoric Acid 75%	R-73F	
Hydrofluosilicic Acid	R-140F	
Hydrofluosilicic Acid 20%	R-140F	
Hydrogen Peroxide 5%	R-180F	R-180F
Hydrogen Peroxide 10%	R-140F	
Hydrogen Peroxide 30%	R-140F	R-104F
Hydrogen Peroxide 50%	R-68F	
Hydrogen Peroxide 90%	NR	
Iodine		
Isobutyl Alcohol	R-140F	
Isopropyl Alcohol	R-150F	
Ketones	NR	R-72F
Lemon Oil	NR	
Lime (Calcium Oxide)	R-73F	
Linseed Oil	R-180F	
Lye Solution/Sod Hydroxide	R-180F	
Machine Oil	R-73F	
Magnesium Chloride	R-180F	
Magnesium Hydroxide	R-180F	
Magnesium Sulfate	R-180F	
Methane	R-73F	
Methanol	R-140F	
Methyl "Cellosolve"	R-73F	
Methyl Alcohol	R-150F	
Methyl Ethyl Ketone	R-68F	
Methylene Chloride	NR	
Mineral Oil	R-100F	R-100F

Chemical Concentrations	PP	FRPP
Mono Chlorobenzene		
Motor Oil	R-73F	
Naphthalene		
Nickel Chloride	R-180F	
Nickel Cyanide		
Nickel Nitrate	R-180F	
Nitric Acid 10%	R-140F	R-72F very slight discoloration
Nitric Acid 30%	R-73F	R-73F slight discoloration
Nitric Acid 50%	R-73F	R-73F slight discoloration
Nitric Acid 70%	NR	NR
Nitric Acid Concentrated	NR	NR
Oils, Cotton Seed	R-150F	
Oils, Mineral	R-100F	
Oils, Vegetable	R-150F	R-150F
Ozone	R-73F	
Peracetic Acid 40%	NR	
Phenol 90%		
Phosphoric Acid 10%	R-180F	R-180F
Phosphoric Acid 50%	R-180F	R-180F
Phosphoric Acid 85%	R-180F	R-180F
Phosphoric Acid 100%	R-73F	R-73F
Photographic Developer	R-104F	R-104F
Photographic Solutions	R-150F	R-150F
Pickle Brine	R-140F	
Pickling Solutions	R-180F	
Plating Solutions		
Antimony	R-180F	
Arsenic	R-150F	
Brass	R-180F	
Bronze	R-180F	
Cadmium	R-73F	
Chrome	R-73F	
Copper	R-180F	
Gold	R-73F	
Indium	R-120F	
Iron	R-140F	
Lead	R-140F	
Nickel	R-140F	
Rhodium	R-140F	
Silver	R-180F	
Tin	R-180F	
Zink	R-180F	
Potash	R-180F	

Chemical Concentrations	PP	FRPP
Potassium Carbonate	R-180F	
Potassium Chloride	R-180F	
Potassium Hydroxide		
Potassium Hydroxide 25%	R-180F	
Potassium Hydroxide 50%	R-73F	
Potassium Permanganate	R-120F	
Potassium Sulfate	R-77F	
Propyl Alcohol	R-140F	
Propylene Glycol	R-100F	
Salt Brine	R-140F	
Silver Nitrate	R-180F	
Silver Sulfate	R-180F	
Soda Ash	R-180F	
Sodium		
Sodium Acetate	R-180F	
Sodium Bicarbonate	R-180F	
Sodium Bisulfate	R-180F	
Sodium Chlorate	R-140F	
Sodium Chloride	R-176F	
Sodium Hydroxide 15%	R-180F	
Sodium Hydroxide 30%	R-180F	
Sodium Hydroxide 50%	R-180F	
Sodium Hydroxide 70%	R-140F	R-140F
Sodium Hydroxide Conc.	R-73F	
Sodium Hypochlorite 20%	R-73F	R-73F
Sodium Peroxide	R-180F	
Sulfuric Acid 10%	R-180F	R-180F
Sulfuric Acid 30%	R-150F	
Sulfuric Acid 50%	R-150F	
Sulfuric Acid 70%	R-120F	
Sulfuric Acid 80%	R-100F	
Sulfuric Acid 90%	R-73F	
Sulfuric Acid 100%	NR	NR
Tetrahydrofuran	NR	
Toluene Toluol	NR	NR
Trichloroacetic Acid	R-120F	
Trichloroethylene	R-73F	
Vegetable Oil	R-180F	
Vinegar	R-180F	
Water, Deionized	R-180F	
Water, Distilled	R-180F	
Water, Potable	R-180F	
Xylene	NR	
Zinc Chloride	R-180F	
Zinc Nitrate	R-180F	
Zinc Salts	R-180F	
Zinc Sulphate	R-180F	

8.2 Hot Water Test

8.2.1 Purpose of Test

The purpose of this test is to insure the coating is resistant to hot water.

8.2.2 Test Procedure

Hot water (190°F to 205°F [88°C to 96°C]) shall be allowed to trickle (with a steady stream and at a rate of not less than 6 ounces [177.44cc] per minute) on the finished surface, which shall be set at an angle of 45°, for a period of five minutes.

8.2.3 Acceptance Level

After cooling and wiping dry, the finish shall show no visible effect from the hot water.

8.3 Impact Test

Not Applicable to Polypropylene

8.4 Paint Adhesion Test

Not Applicable to Polypropylene

8.5 Paint Hardness Test

Not Applicable to Polypropylene

8.6 Dart Impact Test

Not Applicable to Polypropylene

8.7 Edge Delaminating Test

Not Applicable to Polypropylene

8.8 Edge Impact Test

Not Applicable to Polypropylene

8.9 Wear Resistance (Abrasion) Test

Not Applicable to Polypropylene

9.0 Wall, Counter Mounted, and Tall Cabinets

9.1 Description of Test Cabinet

Evaluation shall be conducted on a wall mountable wall cabinet should be double door design cabinet with nominal dimensions as follows: 48" (1,219.2mm) wide, 30" (762mm) high, and 12" (304.8mm) deep. The wall cabinet

shall be manufactured to manufacturers' standard construction and practices. Door loading procedures are outlined under Section 5.0 (Doors). The wall cabinet will be provided with the manufacturer's standard number of shelves. Shelves shall be evaluated per Section 7.0 (Shelves). The unit and shelves shall be mounted in a manner recommended by the manufacturer. A visual examination shall be conducted to verify that the configuration and installation comply with these conditions (see Figure 11). Discontinue evaluation if unit is not in compliance or if malfunction is noted.

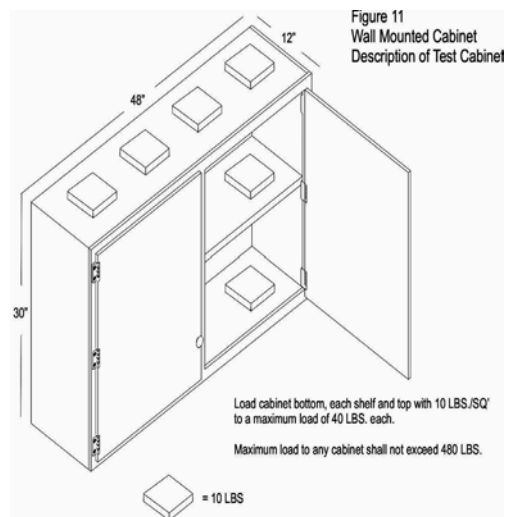

9.2 Load Test

9.2.1 Purpose of Test

The wall mounted load test will demonstrate the strength of the back of the wall cabinet as well as the joinery of the cabinet and function of doors when the unit is subjected to loads normally expected for laboratory furniture.

9.2.2 Test Procedure

Using sand or shot bags weighing 10 pounds (4.536 Kg) each, load cabinet bottom, each shelf, and top uniformly with 10 pounds (4.536 Kg) per square foot to a maximum of 40 pounds (18.144 Kg) each. Maximum load to any cabinet shall not exceed 480 pounds (217.72 Kg) (a maximum of 200 pounds [90.719 Kg] loaded to each bottom, a minimum of one shelf loaded per Section 7.0, and the top) regardless of the number of shelves.

9.2.3 Acceptance Level

With weights in place, operate doors through full travel to verify normal operation of doors. Remove weights and operate doors to verify normal operation. Verify that there is no significant permanent deflection of cabinet top, cabinet back, cabinet bottom, or shelves. After weights are removed, the cabinet shall show no permanent damage to the cabinet, cabinet bottom, or shelves.

10.0 Tables

10.1 Description of Test Unit

The table for evaluation shall be a standing height, four legged, free standing table. The table shall be nominally 60" (1,524mm) long, 24" (609.6mm) deep, and 36" (914.4mm) high (see: Figure 12). Leg and apron size and construction shall be to manufacturer's specification. A top of 1" (25.4mm) thick 37 - 50 pcf medium density fiberboard shall be positioned on the table in a manner recommended by the manufacturer. The top dimensions will be such that it will overhang the cabinet perimeter by 1" (25.4mm). Its weight shall be included in the test as live load.

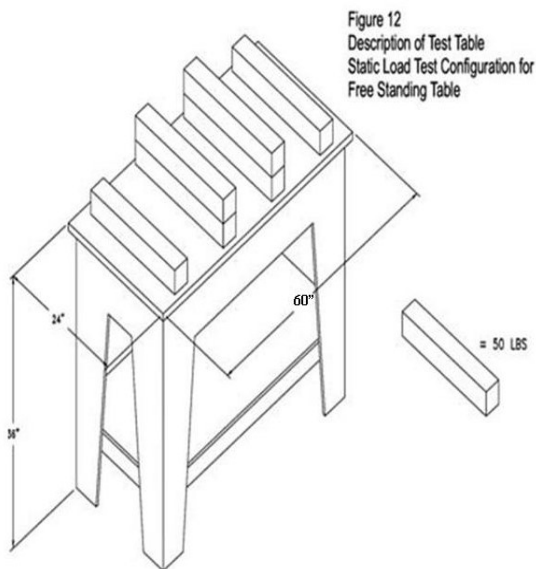

Polypropylene tables can be represented by a very large range of styles and designs. Products inclusive in this section of testing are: Free

Standing Tables, Desks, Aprons mounted between two fixed areas such as a wall or Casework, Mobile Tables (Free Standing Tables on wheels or casters), Mobile Under Counter Units, Mobile Workstations, Adjustable Tables, Modular Tables, C-Frame

Tables, L-Frame Tables, J-Frame Tables, and Tables for systems furniture. These table systems can all be classified as one of three types of tables; Fixed, Free Standing, and Mobile.

10.2 Table Static Load For Free Standing Polypropylene Table

10.2.1 Test Purpose of Test

This test will challenge the table components to loads that are normal for use in a laboratory.

10.2.2 Test Procedure

Load the table top by using solid steel bars (per Section 3.1), each weighing 50 pounds (22.68 Kg), stacked evenly and spaced per Figure 12. These evenly distributed loads should be no less than 300 pounds (136.08 Kg). Include the weight of the working surface as live load.

10.2.3 Acceptance Level

No structural breakage shall result from application of the load. With the full load, the apron rails shall not deflect more than 1/360 of the span of the table and not to exceed 1/8" (3.175mm). In the case of a table with a drawer, the deflection of the rail shall not interfere with the function of the drawer. After the load is removed, inspect the table for structural damage.

10.3 Table Racking Not Applicable to Polypropylene

11.0 Mobile Casework

11.1 Description of Test Cabinet

Test cabinet to have 3 equal drawers on the face and finished both sides and back. The top to have an integral finished worksurface or an applied MDF worksurface not to exceed 1" in thickness nor surpass 1" in overhang beyond

the cabinet on all 4 sides. The test cabinet to measure 24" wide x 22" deep x 30" high (with casters). The inside depth of the drawers shall be no less than 18"(457.2mm). The drawer in the full open position shall expose no less than 2/3 of the drawer interior.

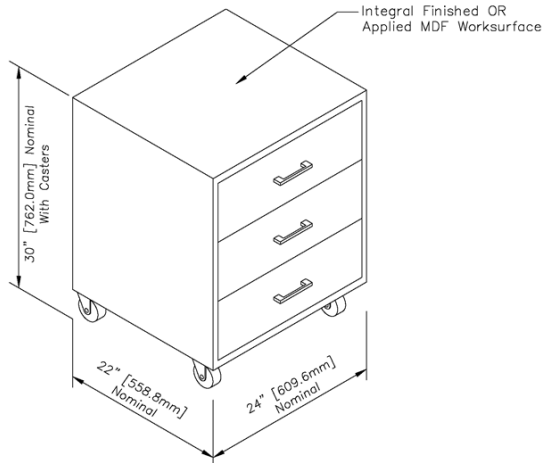

11.2 Static Stability Test

11.2.1 Purpose of Test

The static stability test will challenge the load bearing capability of the mobile base cabinet construction. This test will demonstrate the ability of the mobile base cabinet to support heavy applied loads without overturning.

11.2.2 Test Procedure

Verify that the cabinet is level and supported only by the casters.

Casters shall be positioned with all casters turned rearward.

Extend the top drawer to fully open.

Manufacturers who choose to test their cabinet without Interlocking Hardware must test and pass the Static Stability Test with all movable elements positioned in their least stable condition. Load the mobile base cabinet top drawer by using 50 pounds (22.68 Kg) of solid steel bars or shot bags evenly distributed within the fully extended top drawer. After five minutes, unload the cabinet.

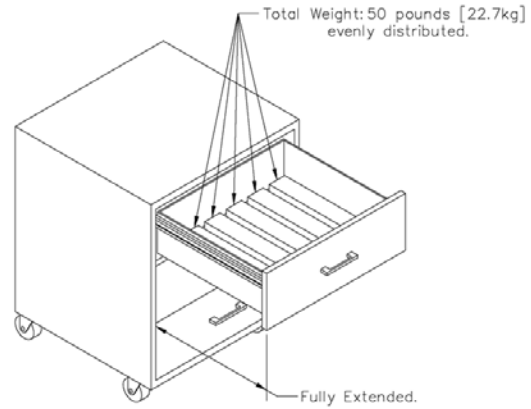

Figure 2. Static Stability Test Configuration

11.2.3 Acceptance Level

The cabinet shall not tip or overturn at any point. Operation of movable elements shall be normal under condition of test load. There shall be no signs of permanent deformation to front rail, cabinet joinery, doors, or drawers.

11.3 Static Load Test

11.3.1 Purpose of Test

The cabinet load test will challenge the structural integrity and load bearing capability of the mobile base cabinet construction. This test will demonstrate the ability of the cabinet to support and operate under heavy applied loads.

11.3.2 Test Procedure

All moveable elements shall be in their closed position for this test.

Verify that the cabinet is level and supported only by the casters.

Load the cabinet top by using 250 pounds (113.4 Kg) of solid steel bars or shot bags evenly distributed.

Each drawer shall be loaded with 50 pounds (22.68 Kg) of solid steel bars or shot bags evenly distributed within each closed drawer.

11.3.3 Acceptance Level

Operation of movable elements shall be normal

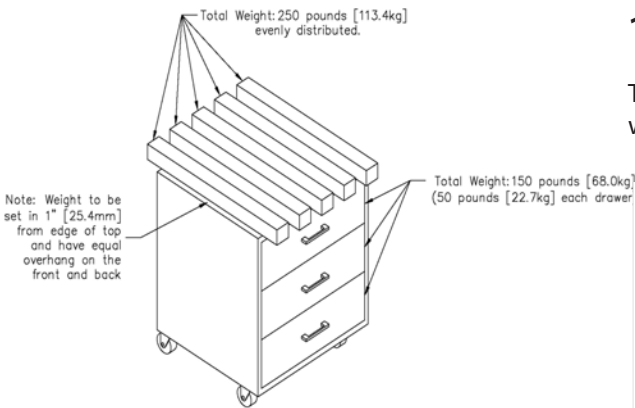

Figure 3. Static Load Test Configuration

under condition of test load. There shall be no signs of permanent deformation to front rail, cabinet joinery, or movable elements.

11.4 Rolling Stability Test

11.4.1 Purpose of Test

This test will demonstrate the durability of the caster, caster attachment and the cabinet's ability to withstand travel over a threshold.

11.4.2 Test Procedure

Prior to conducting the test, a static load of 50 pounds (22.68kg) (using 5 ten 10-pound (4.54kg) sandbags per Section No. 3.1) shall be evenly distributed in each drawer. Secure a threshold (per Section No. 3.1) to the floor or blocked off from a wall far enough for the cabinet to completely travel over. Starting at the threshold, place a line of masking tape on the floor, every 0.8 meters, perpendicular to the threshold, a minimum of 8m of total length, if possible. The tape can also be placed every 0.4 meters with a pace of 120 beats per minute to achieve 0.8m/second. Using a metronome or smartphone app to make one click/beat every second (or alternatively 120 beats per minute) ensures the cabinet is traveling at 0.8m/second. Push the cabinet at its top, so that it is traveling over the masking tape at the same point every beat. The side of the cabinet shall be parallel to the direction of travel and moveable elements shall face the person pushing the cabinet. Continue to push the cabinet over the threshold at this pace.

11.4.3 Acceptance Level

The cabinet shall travel up and over the threshold without permanent damage or overturn.

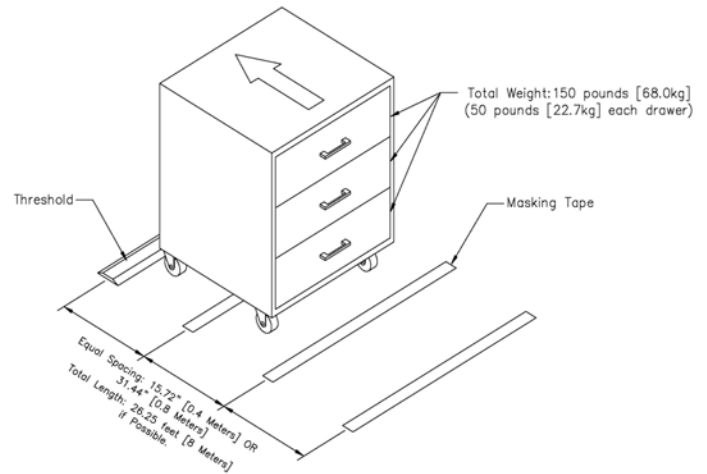

Figure 4. Rolling Stability Test Configuration

Endnotes:

- 1 This format has been adapted from the BIFMA American National Standard format, X5.5 - 1989.
- 2 Ibid. p 8.
- 3 Ibid. pp 10-26.
- 4 The Concise American Heritage Dictionary, (Boston: Houghton Mifflin Company, 1969), p. 38.
- 5 Architectural Woodwork Institute, Architectural Woodwork Quality Standards Illustrated, 7th Edition Version 1.0, 1997, p A-563.
- 6 A. Merriam-Webster, Webster's Ninth New Collegiate Dictionary, (Massachusetts: Merriam-Webster Inc.1988), p 381.
- 7 BIFMA, American National Standard for Office Furnishings, (ANSI/BIFMA X5.5-1983), p 8-9.
- 8 Webster's Ninth New Collegiate Dictionary, 1988, p 980.

SEFA 8 Comparison Chart - August 2025

	8-M	8-PH	8-PL	8-P	8-W
Base Cabinet Test Unit	48" W x 36" H x 22" D	48" W x 36" H x 22" D	48" W x 36" H x 22" D	48" W x 36" H x 22" D	48" W x 36" H x 22" D
4.2 Cabinet Load Test	2000 lbs for 10 minutes	2000 lbs for 24 hours	2000 lbs for 24 hours	1600 lbs for 10 minutes	2000 lbs for 24 hours
4.3 Cabinet Concentrated Load Test	200 lbs	200 lbs	200 lbs	160 lbs	200 lbs
4.4 Cabinet Torsion	200 lbs for 24 hours	200 lbs for 24 hours	200 lbs for 24 hours	160 lbs for 15 minutes	200 lbs for 24 hours
4.5 Cabinet Submersion	N/A	24" water for 4 hours	2" water for 24 hours/48 hour dry	24" water for 4 hours	2" water for 4 hours
4.6 Spill Containment	N/A	N/A	N/A	Fill with water to 1/8" of top of bottom rail - No leakage	N/A
5.0 Door Hinge Test	200 lbs	200 lbs	160 lbs	120 lbs	200 lbs
5.2 Door Impact Test	20 lbs = 240 in/lb impact	N/A	N/A	10 lbs = 190 in/lb impact	N/A
5.3 Door Cycle Test	100,000 cycles	100,000 cycles	100,000 cycles	50,000 cycles	100,000 cycles
6.1 Drawer Static Test	150 lbs	150 lbs	150 lbs	120 lbs	150 lbs
6.2 Drawer and Door Pull Test	50 lbs for 15 seconds	N/A	N/A	40 lbs	N/A
6.3 Drawer Impact Test	10 lbs / 24" High	10 lbs / 24" High	10 lbs / 24" High	8 lbs / 24" High	10 lbs / 24" High
6.4 Drawer Internal Rolling Impact	10 lbs / 13" High	10 lbs / 13" High	10 lbs / 13" High	10 lbs / 13" High	10 lbs / 13" High
6.5 Drawer Cycle Test	100 lbs / 50,000 cycles	75 lbs / 50,000 cycles	100 lbs / 50,000 cycles	10 lbs / 25,000 cycles	75 lbs / 50,000 cycles
7.2 Shelf Load Test	40 lbs/SF / 200 lb max / 0.25" Def	40 lbs/SF / 200 lb max / 0.25" Def	40 lbs/SF / 200 lb max / 0.25" Def	10 lbs/SF / 75 lb max / 0.25" Def	40 lbs/SF / 200 lb max / 0.25" Def
8.1 Chemical Spot Test	No more than four Level 3	No more than four Level 3	No more than four Level 3	No Level 3. Additional chemical resistance data available.	No more than four Level 3
8.2 Hot Water Test	190 to 205 degree for 5 min	190 to 205 degree for 5 min	ANSI/NEMA LD 3-2005 Para 3.5 Boiling Water Res - No change in color or surface finish.	190 to 205 degree for 5 min	190 to 205 degree for 5 min
8.3 Impact Test	1 lb ball / 12" High	N/A	ANSI/NEMA LD 3-2005 Para 3.8 Ball Impact Res. - Min of 50"	N/A	N/A
8.4 Paint Adhesion Test	4B Rating or better	N/A	N/A	N/A	N/A
8.5 Paint Hardness Test	4H Pencil w/o penetration	N/A	N/A	N/A	N/A
8.6 Dart Impact Test	N/A	N/A	ANSI/NEMA LD 3-2005 Para 3.9 Dart Impact Resistance - Min of 20"	N/A	N/A
8.7 Edge Delamination Test	N/A	N/A	Peel value greater than 18.5 lbs/in	N/A	N/A
8.8 Edge Impact Test	N/A	N/A	No signs of damage after impact	N/A	N/A
8.9 Wear Resistance Test	N/A	N/A	ANSI/NEMA LD 3-2005 Para 3.13 Wear Resistance	N/A	N/A
Wall Mounted Test Unit	48" W x 30" H x 12" D	48" W x 30" H x 12" D	48" W x 30" H x 12" D	48" W x 30" H x 12" D	48" W x 30" H x 12" D
9.2 Wall Cabinet Load Test	200 lb max/shelf / 600 lb max	200 lb max/shelf / 600 lb max	200 lb max/shelf / 600 lb max	40 lb max/shelf / 480 lb max	200 lb max/shelf / 600 lb max
Table Test Unit	60" W x 36" H x 24" D	N/A	60" W x 36" H x 24" D	60" W x 36" H x 24" D	60" W x 36" H x 24" D
10.2 Table Static Load	600 lbs / 1/8" Deflection	N/A	300 lbs mobile, 600 lbs free standing, 2000 lbs fixed / 1/8" Deflection	300 lbs / 1/8" Deflection	300 lbs mobile, 600 lbs free standing, 2000 lbs fixed / 1/8" Deflection
10.3 Table Racking	250 lbs	N/A	250 lbs	N/A	250 lbs
Mobile Test Unit	24" W x 22" D x 30" H w/casters	24" W x 22" D x 30" H w/casters	24" W x 22" D x 30" H w/casters	24" W x 22" D x 30" H w/casters	24" W x 22" D x 30" H w/casters
11.1.2 Static Stability Test	50 lbs 5 Mins /No deformation	50 lbs 5 Mins /No deformation	50 lbs 5 Mins /No deformation	50 lbs 5 Mins /No deformation	50 lbs 5 Mins /No deformation
11.1.3 Static Load	250 lbs/top; 50 lbs per drawer no deformation	250 lbs/top; 50 lbs per drawer no deformation	250 lbs/top; 50 lbs per drawer no deformation	250 lbs/top; 50 lbs per drawer no deformation	250 lbs/top; 50 lbs per drawer no deformation
11.1.4 Rolling Stability	50 lbs per drawer - no perm damage or overturn	50 lbs per drawer - no perm damage or overturn	50 lbs per drawer - no perm damage or overturn	50 lbs per drawer - no perm damage or overturn	50 lbs per drawer - no perm damage or overturn

LABORATORY FURNITURE CERTIFICATE OF PERFORMANCE

_____ certifies that its laboratory furniture identified as
(Company Name)

_____, has been tested in conformance with the full requirements
(Test Unit)

of the **SEFA 8-P-2026 Standard**. Testing was performed by a SEFA-approved Independent Third Party Test Lab with results noted below.

Full documentation of the test results is available upon request in a bound report that includes a detailed description of the test unit and procedures, witnesses results and appropriate drawings or photographs of the test unit and procedures.

TEST	TEST RESULTS PASS/FAIL	TEST	TEST RESULTS PASS / FAIL	TEST	TEST RESULTS PASS/ FAIL
4.2		5.3		8.1	<i>See Attached Form</i>
4.3		6.1		8.2	
4.4		6.2		9.2	
4.5		6.3		10.2	
4.6		6.4			
5.1		6.5			
5.2		7.2			

COMPANY INFORMATION	TEST SUPERVISOR INFORMATION
Name:	Name:
Address:	Title:
	Signature:
Telephone:	COMPANY OFFICER INFORMATION
Fax:	Name:
	Title:
Date:	Signature:

CHEMICAL RESISTANCE TESTING – 8-P-2026

Date of Test: _____ Sample Description: _____

Type of Material Coated: _____ Coating Type: _____

Rating Scale: Level 0 – No Detectable Change

Level 1 – Slight Change in Color or Gloss

Level 2 – Slight Surface Etching or Severe Staining

Level 3 – Pitting, Cratering, Swelling, Erosion of Coating. Obvious and Significant Deterioration.

Test No.	Chemical Reagent	Rating	Comments
1.	Acetate, Amyl		
2.	Acetate, Ethyl		
3.	Acetic Acid, 98%		
4.	Acetone		
5.	Acid Dichromate, 5%		
6.	Alcohol, Butyl		
7.	Alcohol, Ethyl		
8.	Alcohol, Methyl		
9.	Ammonium Hydroxide, 28%		
10.	Benzene*		
11.	Carbon Tetrachloride		
12.	Chloroform		
13.	Chromic Acid, 60%		
14.	Cresol		
15.	Dichloroacetic Acid		
16.	Dimethylformamide		
17.	Dioxane		
18.	Ethyl Ether		
19.	Formaldehyde, 37%		
20.	Formic Acid, 90%		
21.	Furfural		
22.	Gasoline		
23.	Hydrochloric Acid, 37%		
24.	Hydrofluoric Acid, 48%		
25.	Hydrogen Peroxide, 30%		
26.	Iodine, Tincture of		
27.	Methyl Ethyl Ketone		
28.	Methylene Chloride		
29.	Mono Chlorobenzene*		
30.	Naphthalene		
31.	Nitric Acid, 20%		
32.	Nitric Acid, 30%		
33.	Nitric Acid, 70%		
34.	Phenol, 90%		
35.	Phosphoric Acid, 85%		
36.	Silver Nitrate Saturated		
37.	Sodium Hydroxide 10%		
38.	Sodium Hydroxide 20%		
39.	Sodium Hydroxide 40%		
40.	Sodium Hydroxide Flake		
41.	Sodium Sulfide Saturated		
42.	Sulfuric Acid, 33%		
43.	Sulfuric Acid, 77%		
44.	Sulfuric Acid, 96%		
45.	Sulfuric Acid 77%& Nitric Acid 70% equal parts		
46.	Toluene		
47.	Trichloroethylene		
48.	Xylene		
49.	Zinc Chloride, Saturated		

TEST PERFORMED BY: _____ DATE: _____